**Road vehicles — Electrical disturbances
from conduction and coupling —**

**Part 2:
Electrical transient conduction along
supply lines only**

*Véhicules routiers — Perturbations électriques par conduction et par
couplage —*

*Partie 2: Perturbations électriques transitoires par conduction
uniquement le long des lignes d'alimentation*



Reference number
ISO 7637-2:2011(E)

© ISO 2011

PDF disclaimer

This PDF file may contain embedded typefaces. In accordance with Adobe's licensing policy, this file may be printed or viewed but shall not be edited unless the typefaces which are embedded are licensed to and installed on the computer performing the editing. In downloading this file, parties accept therein the responsibility of not infringing Adobe's licensing policy. The ISO Central Secretariat accepts no liability in this area.

Adobe is a trademark of Adobe Systems Incorporated.

Details of the software products used to create this PDF file can be found in the General Info relative to the file; the PDF-creation parameters were optimized for printing. Every care has been taken to ensure that the file is suitable for use by ISO member bodies. In the unlikely event that a problem relating to it is found, please inform the Central Secretariat at the address given below.



COPYRIGHT PROTECTED DOCUMENT

© ISO 2011

All rights reserved. Unless otherwise specified, no part of this publication may be reproduced or utilized in any form or by any means, electronic or mechanical, including photocopying and microfilm, without permission in writing from either ISO at the address below or ISO's member body in the country of the requester.

ISO copyright office
Case postale 56 • CH-1211 Geneva 20
Tel. + 41 22 749 01 11
Fax + 41 22 749 09 47
E-mail copyright@iso.org
Web www.iso.org

Published in Switzerland

Contents

Page

Foreword	iv
1 Scope	1
2 Normative references	1
3 Terms and definitions	1
4 Test procedure	1
4.1 General	1
4.2 Test temperature and supply voltages	2
4.3 Voltage transient emissions test	2
4.4 Transient immunity test	6
5 Test instrument description and specifications	9
5.1 Artificial network	9
5.2 Shunt resistor R_S	10
5.3 Switch S	10
5.4 Power supply	11
5.5 Measurement instrumentation	12
5.6 Test pulse generator for immunity testing	12
Annex A (informative) Example of test pulse severity levels associated with function performance status classification	17
Annex B (normative) Transient emissions evaluation — Voltage waveform	19
Annex C (normative) Test pulse generator verification procedure	23
Annex D (informative) Determination of pulse generator energy capability	26
Annex E (informative) Origin of transients in the electric system of road vehicles	30
Annex F (informative) Alternative transient testing technique using electromechanically switched inductive loads	33
Bibliography	43

Foreword

ISO (the International Organization for Standardization) is a worldwide federation of national standards bodies (ISO member bodies). The work of preparing International Standards is normally carried out through ISO technical committees. Each member body interested in a subject for which a technical committee has been established has the right to be represented on that committee. International organizations, governmental and non-governmental, in liaison with ISO, also take Part in the work. ISO collaborates closely with the International Electrotechnical Commission (IEC) on all matters of electrotechnical standardization.

International Standards are drafted in accordance with the rules given in the ISO/IEC Directives, Part 2.

The main task of technical committees is to prepare International Standards. Draft International Standards adopted by the technical committees are circulated to the member bodies for voting. Publication as an International Standard requires approval by at least 75 % of the member bodies casting a vote.

Attention is drawn to the possibility that some of the elements of this document may be the subject of patent rights. ISO shall not be held responsible for identifying any or all such patent rights.

ISO 7637-2 was prepared by Technical Committee ISO/TC 22, *Road vehicles*, Subcommittee SC 3, *Electrical and electronic equipment*.

This third edition cancels and replaces the second edition (ISO 7637-2:2004), which has been technically revised. It also incorporates the Amendment ISO 7637-2:2004/Amd.1:2008. It does not specify test pulses 4, 5a, and 5b, which are now specified in ISO 16750-2 and ISO 21848.

ISO 7637 consists of the following parts, under the general title *Road vehicles — Electrical disturbances from conduction and coupling*:

- *Part 1: Definitions and general considerations*
- *Part 2: Electrical transient conduction along supply lines only*
- *Part 3: Electrical transient transmission by capacitive and inductive coupling via lines other than supply lines*

Road vehicles — Electrical disturbances from conduction and coupling —

Part 2: Electrical transient conduction along supply lines only

1 Scope

This part of ISO 7637 specifies test methods and procedures to ensure the compatibility to conducted electrical transients of equipment installed on passenger cars and commercial vehicles fitted with 12 V or 24 V electrical systems. It describes bench tests for both the injection and measurement of transients. It is applicable to all types of road vehicles independent of the propulsion system (e.g. spark ignition or diesel engine, electric motor).

Function performance status classification for immunity to transients is given in Annex A.

2 Normative references

The following referenced documents are indispensable for the application of this document. For dated references, only the edition cited applies. For undated references, the latest edition of the referenced document (including any amendments) applies.

ISO 7637-1, *Road vehicles — Electrical disturbances from conduction and coupling — Part 1: Definitions and general considerations*

3 Terms and definitions

For the purposes of this document, the terms and definitions given in ISO 7637-1 apply.

4 Test procedure

4.1 General

Methods for measuring the transient emission on supply lines and test methods for the immunity of devices against such transients are given. These tests, called “bench tests”, are performed in the laboratory.

The bench test methods, some of which require the use of the artificial network, will provide comparable results between laboratories.

A bench test method for the evaluation of the immunity of a device against supply line transients may be performed by means of a test pulse generator. This may not cover all types of transients which can occur in a vehicle; therefore, the test pulses described in 5.6 are characteristic of typical pulses.

In special cases, it may be necessary to apply additional test pulses. However, some test pulses may be omitted if a device, depending on its function or its connection, is not influenced by comparable transients in the vehicle. It is part of the vehicle manufacturer's responsibility to define the test pulses required for a specific device.

4.2 Test temperature and supply voltages

The ambient temperature during the test shall be $(23 \pm 5) ^\circ\text{C}$.

The supply voltages shall be as shown in Table 1 unless other values are agreed upon by the users of this part of ISO 7637, in which case such values shall be documented in the test reports.

U_A is the supply voltage defined in Table 1, which shall be measured at the output of the pulse generator.

Table 1 — Supply voltages

Supply voltage	Nominal 12 V system V	Nominal 24 V system V
U_A	$13,5 \pm 0,5$	27 ± 1

4.3 Voltage transient emissions test

4.3.1 General

This clause defines a test procedure to evaluate automotive electrical and electronic components for conducted emissions of transients along battery fed or switched supply lines of a device under test (DUT). A DUT which is considered a potential source of conducted disturbances should be tested according to the procedure described in this clause.

Care shall be taken to ensure that the surrounding electromagnetic environment does not interfere with the measurement set-up.

The test method applies to DUT with or without internal mechanical or electronic switch driving inductive loads.

Voltage transients from the disturbance source, the DUT, are measured using the artificial network to standardize the impedance loading on the DUT (see 5.1).

All wiring connections between the artificial network, switch, and the DUT shall be spaced (50 ± 5) mm above the metal ground plane.

The cable sizes shall be chosen in accordance with the real situation in the vehicle, i.e. the wiring shall be capable of handling the operating current of the DUT, and as agreed between vehicle manufacturer and supplier.

Grounding of the DUT case to the ground plane shall reflect the vehicle installation and shall be defined in a test plan.

If no requirements are specified in the test plan, then the DUT shall be placed on a non-conductive material (50 ± 5) mm above the ground plane.

The supply voltage U_A and the disturbance voltage shall be measured (see 4.3.2 and 4.3.3 for measurement guidance) using a voltage probe (see 5.5) and an oscilloscope or waveform acquisition equipment.

For values, see Annex B.

DUT operating conditions of particular interest in the measurements are the switch-off and the exercising of the various operating modes of the DUT. Exact operating conditions of the DUT shall be specified in the test plan.

NOTE Measurements at turn-on can be of interest in some instances.

The sampling rate and trigger level shall be selected to capture a waveform displaying the complete duration of the transient, and with sufficient resolution to display the highest positive and negative portions of the transient.

Utilising the proper sampling rate and trigger level, the voltage amplitude shall be recorded by actuating the DUT according to the test plan. Other transient parameters, such as rise time, fall time, transient duration, etc. may also be recorded. Unless otherwise specified, ten waveform acquisitions are necessary. It is necessary to report only the waveforms with the highest positive and negative amplitude (with their associated parameters).

The measured transient shall be evaluated in accordance with Annex B. All pertinent information and test results shall be reported. If required per test plan, include transient evaluation results with respect to the performance objective as specified in the test plan.

The test applies to an inductive load (such as power window, power seat, relay, electric mirror, etc.) with a large inductance or a high load current, which connects to the vehicle power supply, or a DUT which switches such an inductive load.

If an inductive load has a small inductance or a low load current and is driven by an internal regulated voltage (e.g. 5 V), which is isolated from the vehicle power supply, the test is not applicable unless specified in a test plan.

4.3.2 Test set-up for slow pulses

The test set-up is described in Figure 1 a).

The disturbance source is connected via the artificial network to the shunt resistor R_s (see 5.2), the switch S (see 5.3) and the power supply (see 5.4).

The switch S represents the main switch (e.g. ignition switch, relay, etc.) which supplies the DUT and could be located at several metres from the DUT.

In the case of a DUT having an internal mechanic and/or electronic switch driving inductive load, the test set-up described in Figure 1 a) is applicable with the DUT internal switch closed (DUT inductive loads powered when opening switch S).

Depending on the DUT internal switch type (relay, electronic switches, IGBT, etc.) it may not be possible to ensure a controlled closure of the internal switch. The detail state of the internal switch(es) shall be recorded in the test report.

Transients generated by the supply disconnection of the DUT are measured at the moment of opening the switch S (the switch S is operated in order to generate transient disturbance).

Dimensions in millimetres
Drawing not to scale

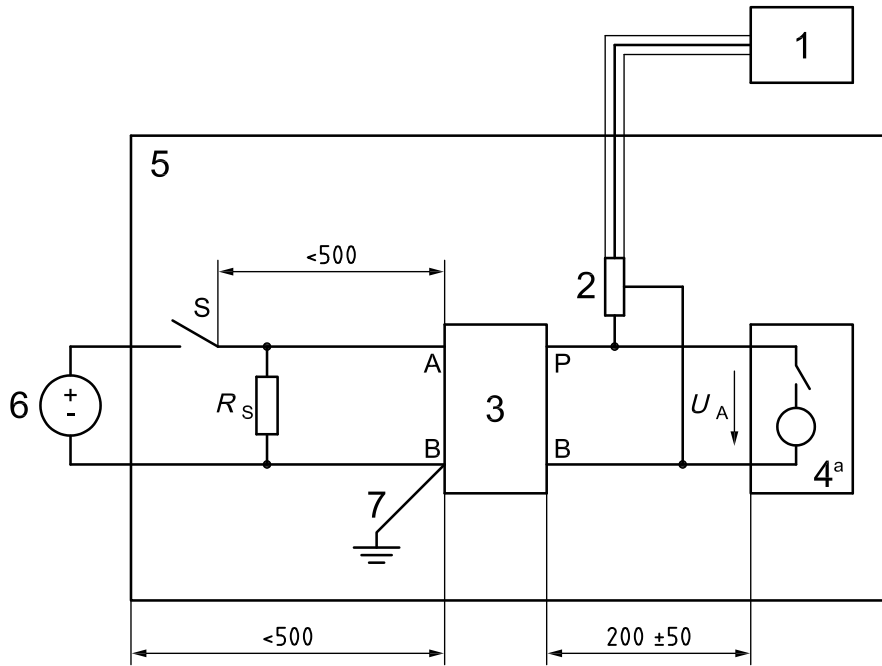

a) Transient emission test set-up to measure slow pulses (ms-range or slower)

Figure 1 — Transient emission test set-up to measure pulses (continued)

4.3.3 Test set-up for fast pulses

The test set-up is described in Figure 1 b) for DUT without internal switch.

The disturbance source is connected via the artificial network to the shunt resistor R_s (see 5.2), the switch S (see 5.3) and the power supply (see 5.4).

Transients generated by the supply disconnection of the DUT are measured at the moment of opening the switch S (the switch S is operated in order to generate transient disturbance).

Dimensions in millimetres
Drawing not to scale

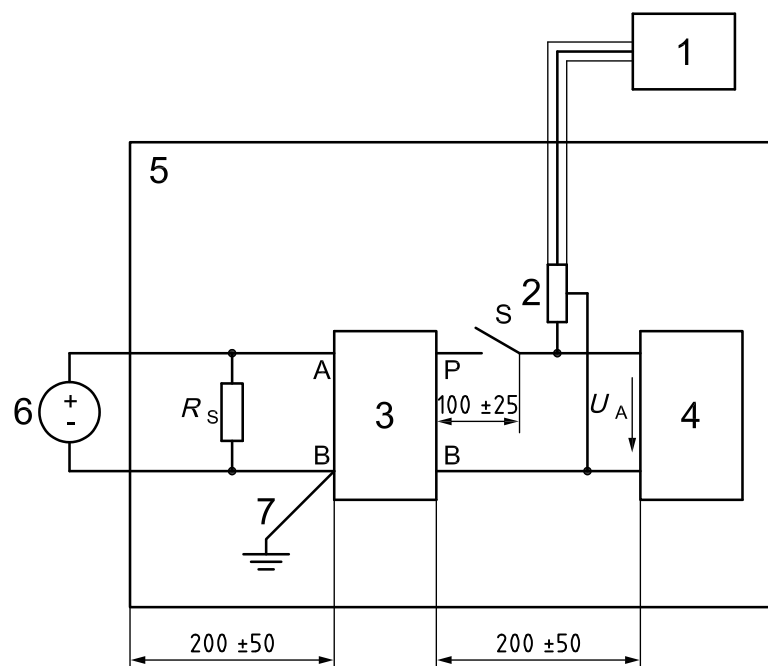

b) Transient emission test set-up to measure fast pulses (ns to μ s range) for DUT without internal switch

Figure 1 — Transient emission test set-up to measure pulses (continued)

The test set-up is described in Figure 1 c) for DUT with internal switch.

The disturbance source is connected via the artificial network to the shunt resistor R_s (see 5.2) and the power supply (see 5.4).

In this case the internal switch shall be operated in order to generate transient disturbance (there is no need for the switch S).

Transients generated by the supply disconnection of the DUT are measured at the moment of opening the internal switch (the switch is operated in order to generate transient disturbance), with the probe connected as close to the DUT terminals as possible.

Dimensions in millimetres
Drawing not to scale

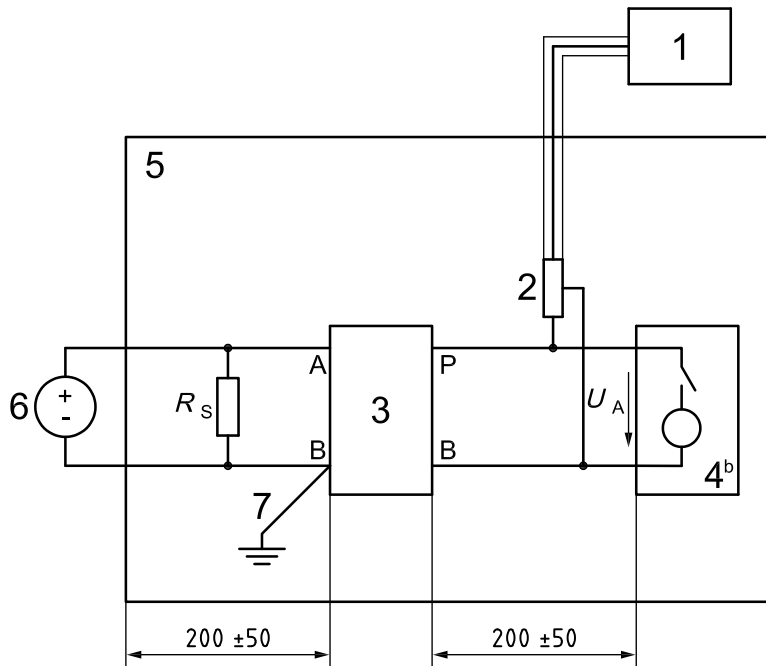

c) Transient emission test set-up to measure fast pulses (ns to μ s range) for DUT with internal switch

Key

- 1 oscilloscope or equivalent
- 2 voltage probe
- 3 artificial network
- 4 DUT (source of transient)
- 5 ground plane
- 6 power supply
- 7 ground connection; length <100 mm
- R_s shunt resistance, as specified in 5.2
- S switch, as specified in 5.3
- U_A supply voltage

NOTE For A, B, and P, see Figure 3.

- ^a Optionally with internal switch driving inductive load.
- ^b With internal load and switch.

Figure 1 — Transient emission test set-up to measure pulses

4.4 Transient immunity test

4.4.1 Location of the DUT

The DUT shall be placed on a non-conductive low relative permittivity ($\epsilon_r \leq 1,4$) support with a thickness of (50 ± 5) mm.

Grounding of the DUT case to the ground plane shall reflect the vehicle installation and shall be defined in a test plan.

4.4.2 Location of the power supply lines

For test pulses 3a and 3b, the leads between the terminals of the test pulse generator and the DUT shall be laid out in a straight parallel line on a low relative permittivity ($\epsilon_r \leq 1,4$) support with a thickness of (50 ± 5) mm and shall have a length of (500 ± 100) mm.

4.4.3 Location of the load simulator

Preferably, the load simulator shall be placed directly on the ground plane. If the load simulator has a metallic case, this case shall be bonded to the ground plane.

Alternatively, the load simulator may be located adjacent to the ground plane (with the case of the load simulator bonded to the ground plane).

4.4.4 Test set-up

Prior to test with the DUT, the test pulse generator is set up [see Figure 2 a)] to provide the specific pulse polarity, amplitude, duration and resistance without DUT (see 5.6). The peak voltage U_s shall be adjusted to be the required test level with the tolerances of +10 % and 0 %.

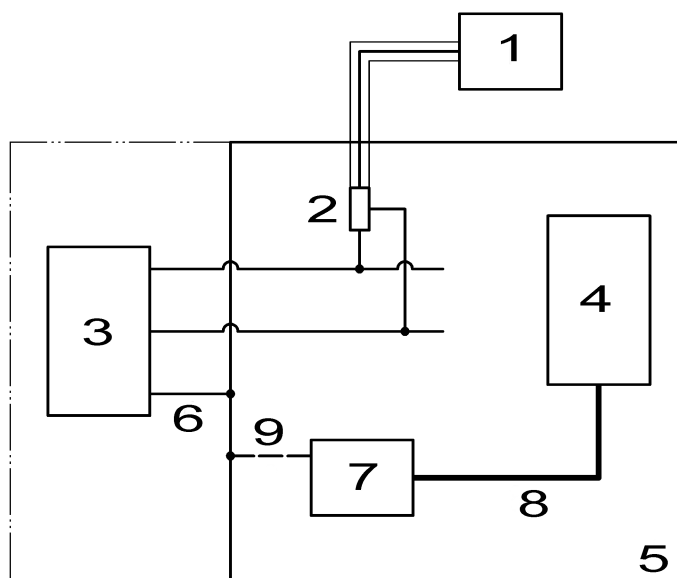

a) Pulse adjustment

Key

- 1 oscilloscope or equivalent
- 2 voltage probe
- 3 test pulse generator
- 4 DUT disconnected
- 5 ground plane
- 6 DC power ground connection; maximum length for test pulse 3 is 100 mm
- 7 load simulator (connected to ground plane if required)
- 8 interconnect cable routed away from DUT power leads under test to avoid coupling
- 9 load simulator ground (if required)

Figure 2 — Transient immunity test set-up (continued)

Next, the DUT is connected to the generator [see Figure 2 b)] while the oscilloscope is disconnected.

Depending on the real conditions, the function of the DUT may be evaluated during and/or after the application of the test pulses.

For correct generation of the required test pulses it may be necessary to switch the power supply on and off. The switching can be performed by the test pulse generator if the power supply is integral to it.

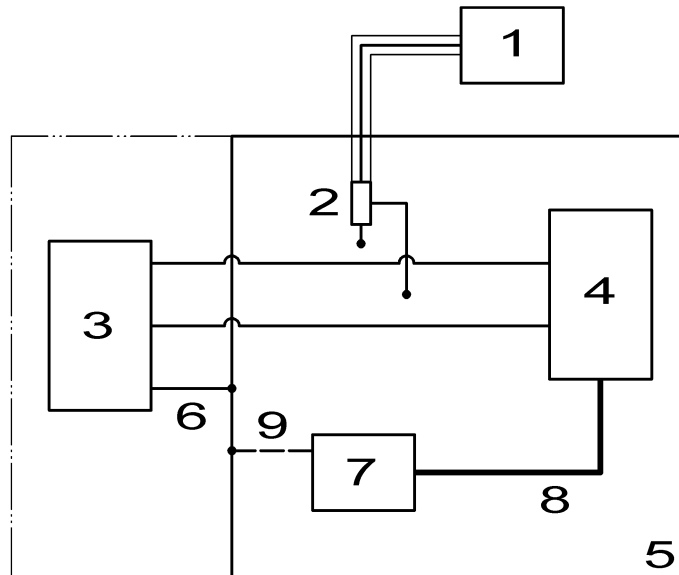

b) Pulse injection

Key

- 1 oscilloscope or equivalent
- 2 voltage probe disconnected
- 3 test pulse generator
- 4 DUT
- 5 ground plane
- 6 DC power ground connection; maximum length for test pulse 3 is 100 mm
- 7 load simulator (connected to ground plane if required)
- 8 interconnect cable routed away from DUT power leads under test to avoid coupling
- 9 load simulator ground (if required)

Figure 2 — Transient immunity test set-up

5 Test instrument description and specifications

5.1 Artificial network

The artificial network is used as a reference standard in the laboratory in place of the impedance of the vehicle wiring harness in order to determine the behaviour of equipment and electrical and electronic devices. An example of a schematic diagram is given in Figure 3.

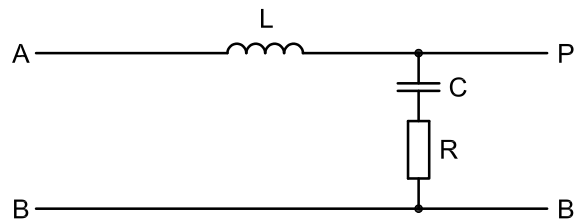

Key

- A power supply terminal
- B common terminal
- C capacitor
- L inductor
- P terminal for the DUT
- R resistor

Figure 3 — Example of a schematic diagram of artificial network

The artificial network shall be able to withstand a continuous load corresponding to the requirements of the DUT.

The resulting values of impedance $|Z_{PB}|$, measured between the terminals P and B while terminals A and B are short-circuited, are given in Figure 4 as a function of frequency assuming ideal electric components. In reality, the impedance of an artificial network shall not deviate more than 10 % from the curve given in Figure 4.

The main characteristics of the components are as follows:

- inductor: $L = 5 \mu\text{H}$ (air-core winding);
- internal resistance between terminals P and A: $<5 \text{ m}\Omega$;
- capacitor: $C = 0,1 \mu\text{F}$ for working voltages of 200 V AC and 1 500 V DC;
- resistor: $R = 50 \Omega$.

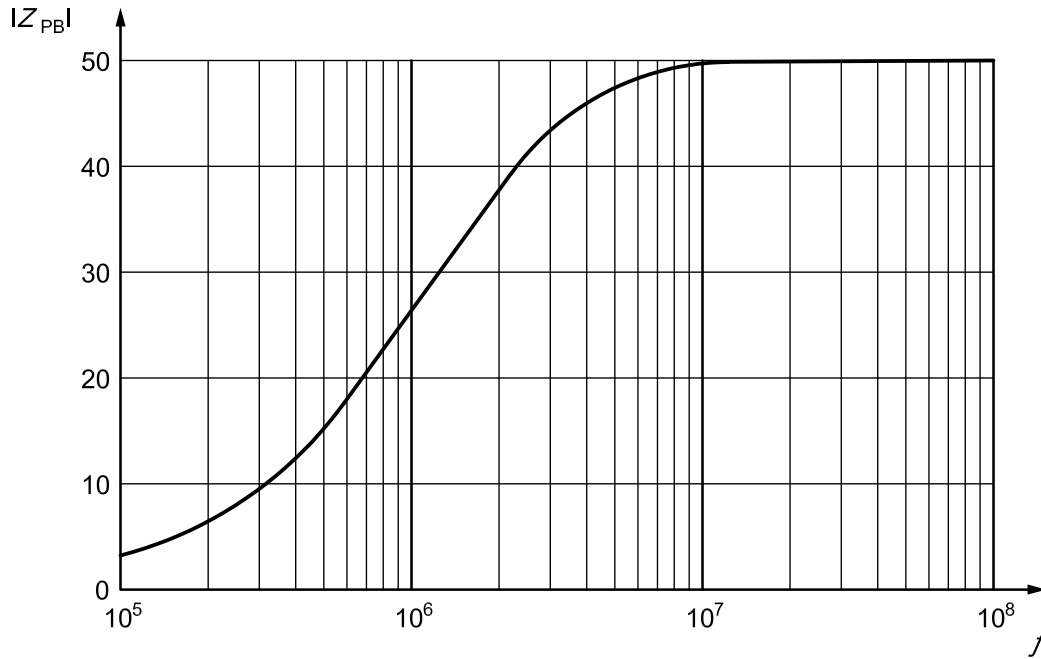

Key

- $|Z_{PB}|$ impedance (Ω)
- f frequency (Hz)

Figure 4 — Impedance $|Z_{PB}|$ as a function of frequency from 100 kHz to 100 MHz (AB short-circuited)

The artificial network shall be placed on the ground plane. The common terminal on the power source end of the artificial network shall be connected to the ground plane as shown in Figures 1 a), 1 b) and 1 c).

5.2 Shunt resistor R_s

The shunt resistor R_s [see Figures 1 a), 1 b) and 1 c)] simulates the impedance of other vehicle devices which are connected in parallel to the DUT and are not disconnected from it by the ignition switch. R_s is selected to correspond to the mean impedance on the wiring harness between the disconnected ignition switch terminal and ground, with the switch off, and shall be specified by the vehicle manufacturer. In the absence of any specification, a value of $R_s = 40 \Omega$ shall be used. If a wire-wound resistor is used, the winding shall be bifilar (i.e. with a minimum reactive component).

NOTE To simulate the worst case condition, R_s can be disconnected.

5.3 Switch S

The switching device S shall be located as shown in Figures 1 a), and 1 b). If the wiring between switch and load is long in the vehicle application (several meters), then using the slow set-up is adequate. If this is not the case, using the fast set-up is more appropriate. In either case, only the fast set-up is appropriate to measure the fast transients that may be generated by an opening relay.

The switch on the DUT side of the artificial network shall be actuated for the measurement of fast transients ($t_d \approx ns$ to μs range).

The switch on the power supply side of the artificial network shall be actuated for the measurement of slow transients ($t_d \approx ms$ range).

As the switch S significantly influences the disturbance transient characteristics, the recommended switching devices are outlined as follows.

- a) For the measurement of high voltage transients (with amplitudes over 400 V), the switching device should be a standard production switch that is used in the vehicle with the DUT. If such a device is not available, an automotive relay with the following characteristics shall be used:
- contact rating: $I = 30$ A, continuous, resistive load;
 - high purity silver contact material;
 - no suppression across relay contact;
 - single/double position contact electrically insulated from the coil circuit;
 - coil with transient suppression (to minimize the effect on measured transient emissions).

NOTE This switching relay tends to degrade with use and needs to be replaced.

- b) An unequivocal assessment of the disturbance is only possible if a switch with reproducible properties is used. For this purpose, an electronic switch is proposed. It is probable that amplitudes of disturbance are higher than those normally encountered with conventional switches (arcing). This shall be taken into account when evaluating test results. The electronic switch is very appropriate for controlling the function of suppressors used. For the measurement of lower voltage transients (with amplitudes less than 400 V) such as those produced by sources with transient suppressions, the switching device is recommended to be an electronic switch with the following characteristics:

- voltage rating: $U_{\max.} = 400$ V minimum at 25 A;
- current rating: $I_{\max.} = 25$ A minimum continuously, 100 A for $\Delta t \leq 1$ s;
- voltage drop: $\Delta U \leq 2$ V at 25 A;
- supply voltages: see Table 1;
- switching time: $\Delta t_s = 300$ ns ± 20 % at 13,5 V with reference load $R = 0,6 \Omega$, $L = 50 \mu\text{H}$ (at 1 kHz);
- trigger: internal and external;
- voltage probe: 1:100.

The switch shall withstand a short-circuit condition.

Some electronic switches may include an artificial network according to 5.1 and Figures 3 and 4. In this case it shall be possible to bypass it and use an external artificial network.

The switch selected for the test shall be defined in a test plan and documented in the test report.

5.4 Power supply

The continuous supply source shall have an internal resistance R_i less than $0,01 \Omega$ DC and an internal impedance $Z_i = R_i$ for frequencies less than 400 Hz. The output voltage shall not deviate more than 1 V from minimum to maximum load (including inrush current) and shall recover 63 % of its maximum excursion within 100 μs . The superimposed ripple voltage, U_r , shall not exceed 0,2 V peak-to-peak. If a standard power supply (with sufficient current capacity) is used to simulate the battery, it is important that the low internal impedance of the battery is also simulated.

When a battery is used, a charging source may be needed to achieve the supply voltage U_A (see Table 1).

CAUTION — If a test is performed while the battery is being charged, care should be taken to minimize the accumulation of hydrogen gas in order to avoid the risk of explosion.

5.5 Measurement instrumentation

A digitizing oscilloscope, or equivalent waveform acquisition equipment with voltage probes, shall be used as measuring equipment along with the following parameters:

- bandwidth: DC to at least 400 MHz;
- sampling rate: at least 2 Gigasamples per second (single sampling mode).

Probe characteristics:

- attenuation: 10/1 (100/1, if needed);
- maximum input voltage: 500 V (1 000 V, if needed);
- bandwidth: DC to at least 400 MHz;
- input impedance: $Z \geq 1 \text{ M}\Omega$ at DC.

5.6 Test pulse generator for immunity testing

The test pulse generator shall be capable of producing the open circuit test pulses described in 5.6.1 to 5.6.4 at the maximum value of $|U_S|$. U_S shall be adjustable within the limits given in Tables 2 to 6.

The timing (t) tolerances and internal resistance (R_i) tolerance shall be $\pm 20\%$ unless otherwise specified.

A verification procedure for the generator performance and tolerances is described in Annex C.

Example values for the evaluation of immunity of devices can be chosen from Tables A.1, A. 2 and A.3.

5.6.1 Test pulse 1

This test is a simulation of transients due to supply disconnection from inductive loads; it applies to a DUT if, as used in the vehicle, it remains connected directly in parallel with an inductive load (see Figure E.1 in Annex E).

The pulse shape is given in Figure 5.

The parameters are given in Table 2.

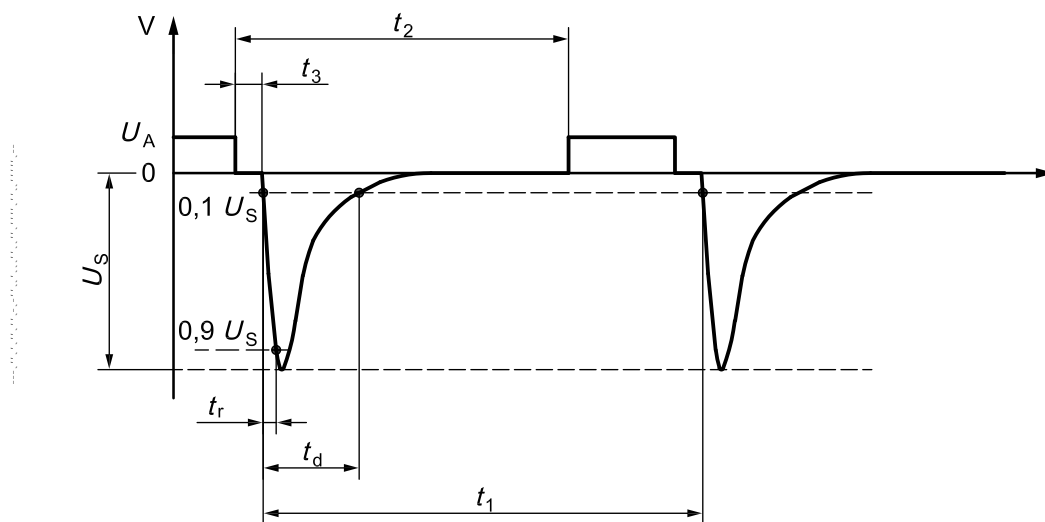

Figure 5 — Test pulse 1

Table 2 — Parameters for test pulse 1

Parameters	Nominal 12 V system	Nominal 24 V system
U_S	-75 V to -150 V	-300 V to -600 V
R_i	10 Ω	50 Ω
t_d	2 ms	1 ms
t_r	$(1 \begin{smallmatrix} 0 \\ -0,5 \end{smallmatrix}) \mu\text{s}$	$(3 \begin{smallmatrix} 0 \\ -1,5 \end{smallmatrix}) \mu\text{s}$
t_1^a	$\geq 0,5 \text{ s}$	
t_2	200 ms	
t_3^b	$< 100 \mu\text{s}$	

^a t_1 shall be chosen such that it is the minimum time for the DUT to be correctly initialized before the application of the next pulse and shall be $\geq 0,5 \text{ s}$.

^b t_3 is the smallest possible time necessary between the disconnection of the supply source and the application of the pulse.

5.6.2 Test pulses 2a and 2b

Pulse 2a simulates transients due to sudden interruption of currents in a device connected in parallel with the DUT due to the inductance of the wiring harness (see Figure E.2 a) in Annex E).

Pulse 2b simulates transients from DC motors acting as generators after the ignition is switched off (see Figure E.2 b) in Annex E).

The pulse shapes and parameters for these test pulses are given in Figures 6 and 7, and Tables 3 and 4, respectively.

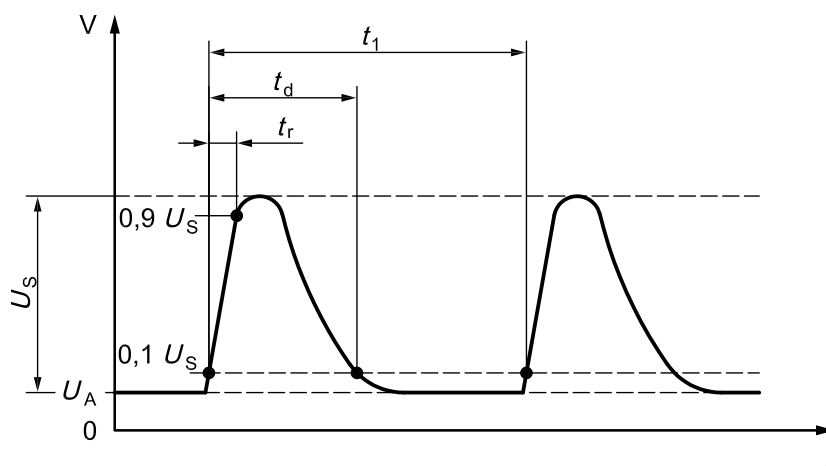

Figure 6 — Test pulse 2a

Table 3 — Parameters for test pulse 2a

Parameters	Nominal 12 V and 24 V system
U_s	+37 V to +112 V
R_i	2 Ω
t_d	0,05 ms
t_r	(1 ⁰ _{-0,5}) μ s
t_1^a	0,2 s to 5 s

^a The repetition time t_1 can be short depending on the switching. The use of a short repetition time reduces the test time.

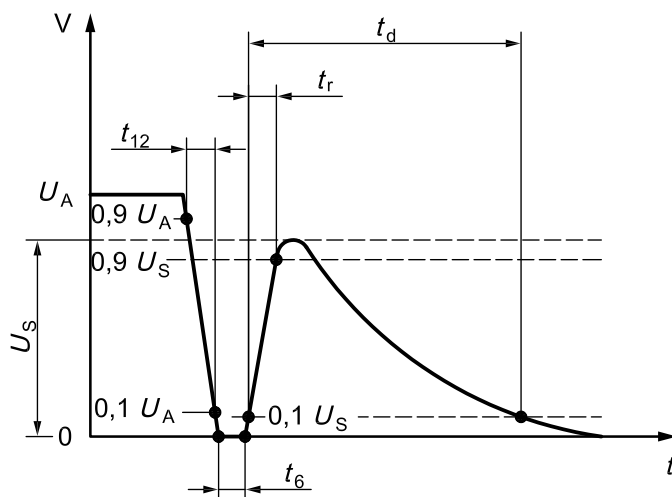

Figure 7 — Test pulse 2b

Table 4 — Parameters for test pulse 2b

Parameters	Nominal 12 V system	Nominal 24 V system
U_s	10 V	20 V
R_i	0 Ω to 0,05 Ω	
t_d	0,2 s to 2 s	
t_{12}	1 ms \pm 0,5 ms	
t_r	1 ms \pm 0,5 ms	
t_6	1 ms \pm 0,5 ms	

5.6.3 Test pulses 3a and 3b

These test pulses are a simulation of transients, which occur as a result of the switching processes. The characteristics of these transients are influenced by distributed capacitance and inductance of the wiring harness (see Figure E.3 in Annex E).

The pulse shapes and parameters for these test pulses are given in Figures 8 and 9, and Tables 5 and 6, respectively.

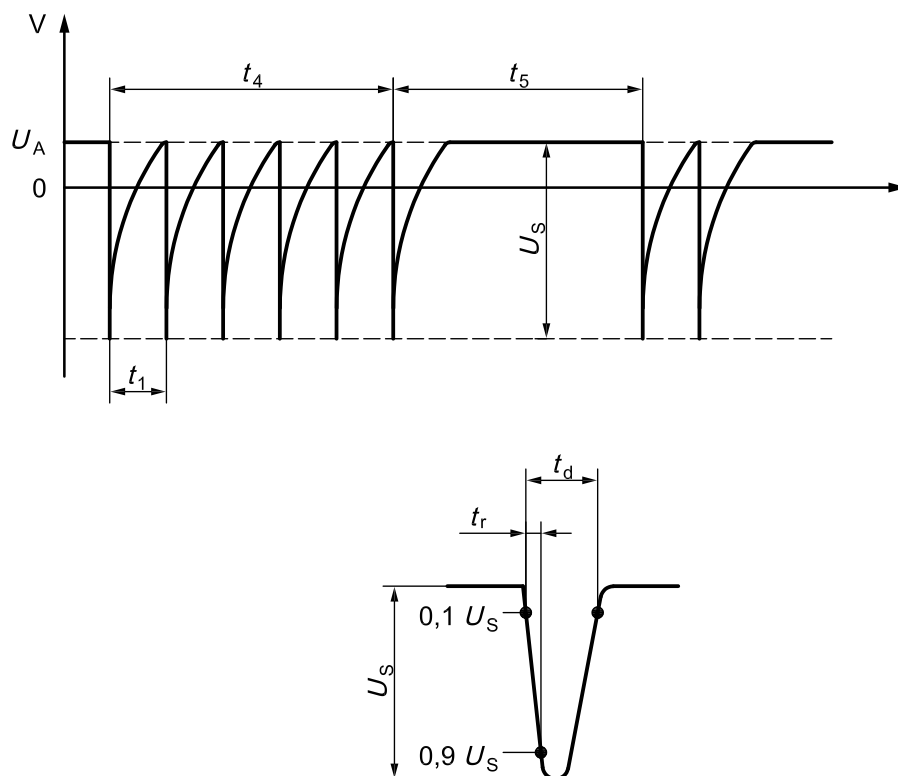

Figure 8 — Test pulse 3a

Table 5 — Parameters for test pulse 3a

Parameters	Nominal 12 V system	Nominal 24 V system
U_s	-112 V to -220 V	-150 V to -300 V
R_i	50 Ω	
t_d	150 ns \pm 45 ns	
t_r	5 ns \pm 1,5 ns	
t_1	100 μ s	
t_4	10 ms	
t_5	90 ms	

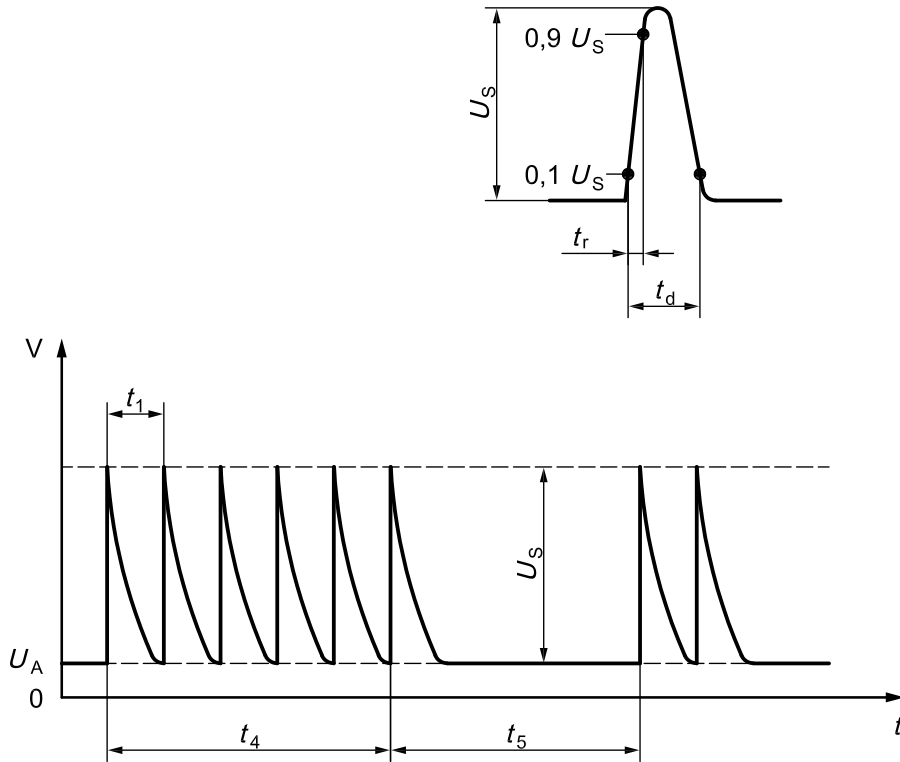

Figure 9 — Test pulse 3b

Table 6 — Parameters for test pulse 3b

Parameters	Nominal 12 V system	Nominal 24 V system
U_s	+75 V to +150 V	+150 V to +300 V
R_i	50 Ω	
t_d	150 ns \pm 45 ns	
t_r	5 ns \pm 1,5 ns	
t_1	100 μ s	
t_4	10 ms	
t_5	90 ms	

5.6.4 Note on test pulses 4, 5a, and 5b

The test pulses 4, 5a, and 5b have been removed from this edition of this part of ISO 7637, since they are specified in ISO 16750-2 and ISO 21848.

Annex A (informative)

Example of test pulse severity levels associated with function performance status classification

A.1 General

This annex gives examples of test pulse severity levels which should be used in line with the principle of function performance status classification (FPSC) described in ISO 7637-1.

A.2 Classification of test pulse severity level

A.2.1

The suggested minimum and maximum severity levels are given in column III and IV in Tables A.1 and A.2.

A selected level and test time for testing at or in between these values may be chosen according to the agreement between vehicle manufacturer and supplier. In cases where no specific values are defined, it is recommended to use levels selected from columns III through IV in Tables A.1 and A.2.

A.2.2 12 V electrical system

The recommended levels are given in Table A.1.

Table A.1 — Examples of test pulse severity levels for nominal 12 V system

Test pulse ^a	Selected test level ^b	Test pulse severity level, U_s^{cd}			Min. number of pulses or test time	Burst cycle/pulse repetition time	
		IV	III	I / II		min.	max.
1		-150	-112	-75	500 pulses	0,5 s	^e
2a		+112	+55	+37	500 pulses	0,2 s	5 s
2b		+10	+10	+10	10 pulses	0,5 s	5 s
3a		-220	-165	-112	1 h	90 ms	100 ms
3b		+150	+112	+75	1 h	90 ms	100 ms

^a Test pulses as in 5.6.
^b Values agreed between vehicle manufacturer and equipment supplier.
^c The amplitudes are the values of U_s as defined for each test pulse in 5.6.
^d The former levels I and II are revised because they did not ensure sufficient immunity in subsequent road vehicles' design.
^e The maximum pulse repetition time shall be chosen such that it is the minimum time for the DUT to be correctly initialized before the application of the next pulse and shall be $\geq 0,5$ s.

A.2.3 24 V electrical systems

The recommended values are given in Table A.2.

Table A.2 — Suggested test pulse severity levels for nominal 24 V system

Test pulse ^a	Selected test level ^b	Test pulse severity level, U_s^{cd} V			Min. number of pulses or test time	Burst cycle/pulse repetition time	
		IV	III	I / II		min.	max.
1		-600	-450	-300	500 pulses	0,5 s	^e
2a		+112	+55	+37	500 pulses	0,2 s	5 s
2b		+20	+20	+20	10 pulses	0,5 s	5 s
3a		-300	-220	-150	1 h	90 ms	100 ms
3b		+300	+220	+150	1 h	90 ms	100 ms

^a Test pulses as in 5.6.
^b Values agreed between vehicle manufacturer and equipment supplier.
^c The amplitudes are the values of U_s as defined for each test pulse in 5.6.
^d The former levels I and II are revised because they did not ensure sufficient immunity in subsequent road vehicles' design.
^e The maximum pulse repetition time shall be chosen such that it is the minimum time for the DUT to be correctly initialized before the application of the next pulse and shall be $\geq 0,5$ s.

A.3 Example of FPSC application using test pulse severity levels

An example of severity levels is given in Table A.3. This table can be different for each kind of pulse, and for 12 V and 24 V electrical systems (levels from Tables A.1 and A.2).

Table A.3 — Examples of test pulse severity levels

	Category 1	Category 2	Category 3
L_{4i}	Level IV	Level IV	Level IV
L_{3i}	Level I / II / III	Level IV	Level IV
L_{2i}	Level I / II / III	Level I / II / III	Level IV
L_{1i}	Level I / II / III	Level I / II / III	Level I / II / III

Annex B (normative)

Transient emissions evaluation — Voltage waveform

B.1 General

The purpose of this annex is to provide a method of evaluation to characterize transient emissions from disturbance sources as tested in accordance with the test conditions specified in 4.2.

B.2 Essential elements of transient emissions waveform characteristics

The following waveform parameters are to be taken into consideration for the evaluation of waveform characteristics (see ISO 7637-1 for definitions).

Abbreviations have been assigned to the waveform parameters as given in Table B.1.

Table B.1 — Terms and abbreviations

Parameter	Definition ISO 7637-1, Clause 3	Abbreviation
Peak amplitude	3.12	$U_s (U_{s1}, U_{s2})$
Pulse duration	3.13.1	t_d
Pulse rise time	3.13.2	t_r
Pulse fall time	3.13.3	t_f
Pulse repetition time	3.14.4	t_1
Burst duration	3.14.1	t_4
Time between bursts	3.14.2	t_5
Burst cycle time	3.14.3	$t_4 + t_5$

B.3 Classification of transient emissions

B.3.1 General

The suggested minimum and maximum limits for transient emissions are given in columns I to IV of Tables B.2 and B.3, respectively, in B.3.7. The acceptable limit at or in between these values may be chosen according to the agreement between vehicle manufacturer and supplier. The transient emissions may have to meet either part of or all the parameters outlined in Table B.1, depending on this agreement. In cases where no specific values are defined, it is recommended that levels selected from columns I to IV of Tables B.2 and B.3, respectively, in B.3.7, be used.

Depending on the test set-up that is used in Figure 1 a) or 1 b) or 1 c), either slower pulses or fast transients will be observed. All types of test set-up shall therefore be used.

The voltage waveforms illustrated in Figures B.1 and B.2 are typical waveforms on the bench top according to the test conditions described in 4.3 of this part of ISO 7637. The application of the voltage emissions limit (U_s) is as follows.

B.3.2 Transient with both positive (U_{s2}) and negative pulses (U_{s1})

Both positive and negative voltage limits shall apply.

B.3.3 Transient with positive pulses (U_{s2})

A positive voltage limit shall apply.

B.3.4 Transient with negative pulses (U_{s1})

A negative voltage limit shall apply.

B.3.5 Transient with single or multiple bursts with positive (U_{s2}) or negative pulses (U_{s1})

The positive and/or negative voltage limit(s) shall apply.

B.3.6 Typical transient waveforms

The essential parameters of single transient and bursts waveforms are illustrated in Figure B.1 and Figure B.2, respectively.

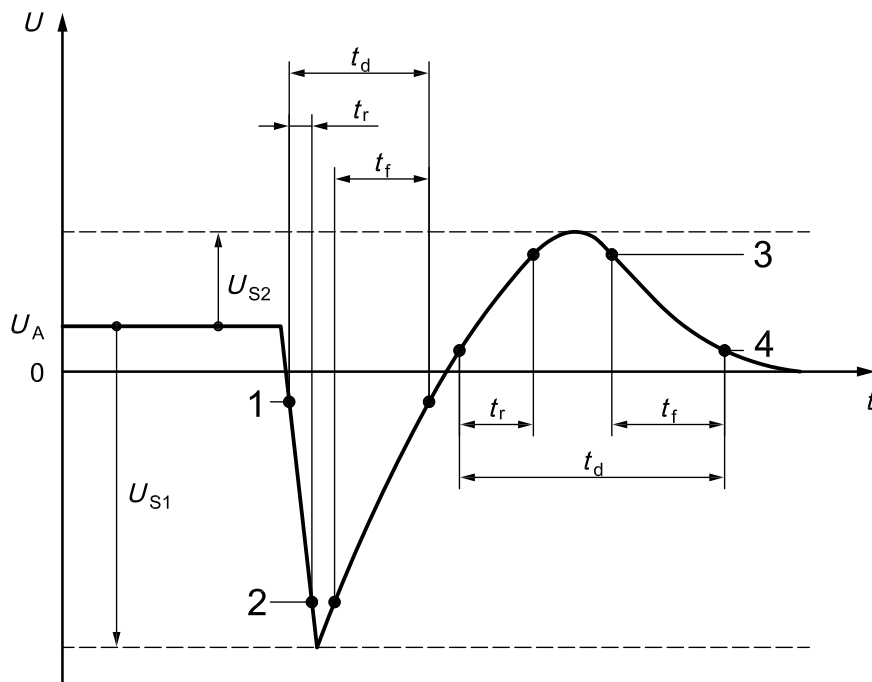

Key

- 1 0,1 ($U_{s1} - U_A$)
- 2 0,9 ($U_{s1} - U_A$)
- 3 0,9 ($U_{s2} + U_A$)
- 4 0,1 ($U_{s2} + U_A$)

Figure B.1 — Single transient waveform

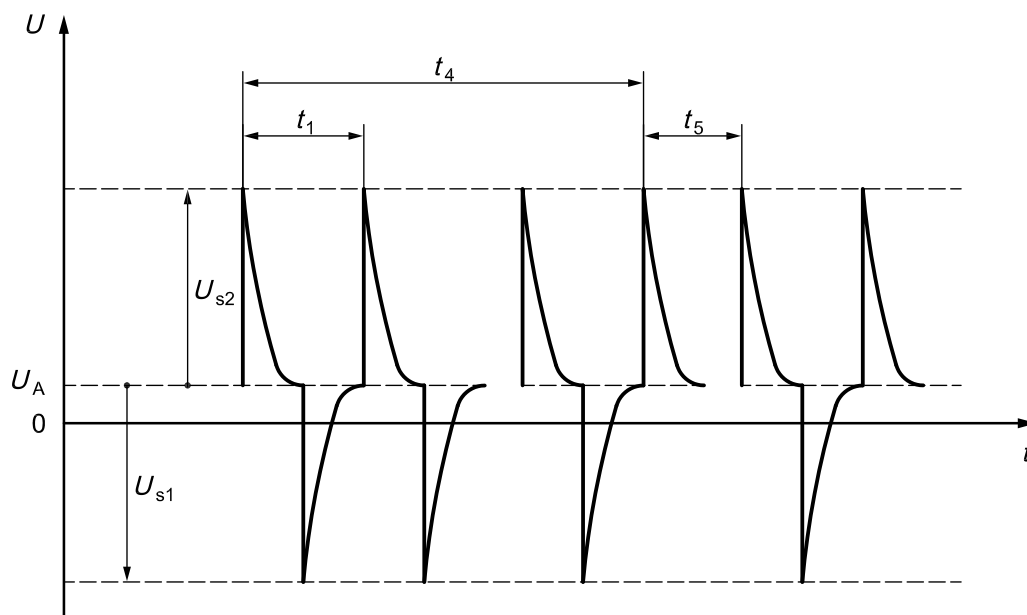

Figure B.2 — Burst transient waveform

B.3.7 Transient waveform classification table

First determine the transient amplitude and waveform measure with the test set-up according to Figure 1 a) for the maximum amplitude of the slower pulses (ms-range). After that, use the test set-up according to Figure 1 b) or 1 c) and determine the maximum amplitude for the fast transients (ns to ms range).

The classification of the transient amplitudes may be performed by applying the values in Tables B.2 and B.3, respectively.

Table B.2 — Suggested limits for the classification of nominal 12 V equipment

Pulse amplitude (U_s)	Suggested limit for U_s for severity levels I to V			
	I / II	III	IV	V ^a
Positive slow pulses (ms range or slower)	+25 V	+37 V	+75 V	
Negative slow pulses (ms range or slower)	-50 V	-75 V	-100 V	
Positive fast pulses (μ s to ns range)	+50 V	+75 V	+100 V	
Negative fast pulses (μ s to ns range)	-75 V	-112 V	-150 V	

^a Values to be determined by vehicle manufacturer and equipment supplier.

Table B.3 — Suggested limits for the classification of nominal 24 V equipment

Pulse amplitude (U_s)	Suggested limit for U_s for severity levels I to V			
	I / II	III	IV	V ^a
Positive slow pulses (ms range or slower)	+25 V	+37 V	+75 V	
Negative slow pulses (ms range or slower)	-100 V	-150 V	-200 V	
Positive fast pulses (μ s to ns range)	+100 V	+150 V	+200 V	
Negative fast pulses (μ s to ns range)	-100 V	-150 V	-200 V	
^a Values to be determined by vehicle manufacturer and equipment supplier.				

Annex C (normative)

Test pulse generator verification procedure

C.1 General

The purpose of this annex is to provide a method for the verification of the output characteristics of the test pulse generator.

See 5.5 for measurement instrumentation requirements.

The verification measurements described in C.2 shall be performed under two different loading conditions to determine the behaviour of the test pulse generator:

- under no load condition;
- under matched load conditions.

C.2 Pulse verification

The generator must be verified to ensure compliance to the parameters listed below for both open circuit and loaded conditions. The energy content may influence significantly the test results. Within the test report the energy of the actual used pulses shall be listed (see Annex D for examples of methods for determining pulse energy).

The U_A for this verification procedure is 0 volts.

Care shall be taken for the selection of the resistors. They shall have sufficient power dissipation for both pulse and DC supply rating. Additionally they shall be non-inductive. The tolerance of the matching resistor shall be $\pm 1\%$.

The source impedance shall be selected to be equal to the load resistance defined for each test pulse.

C.2.1 Test pulse 1

C.2.1.1 Test pulse 1 (Nominal 12 V system)

Table C.1 — Test pulse 1 (Nominal 12 V system)

Test pulse 1	U_s	t_r	t_d
No load	$-100 \text{ V} \pm 10 \text{ V}$	$(1 \begin{smallmatrix} 0 \\ -0,5 \end{smallmatrix}) \mu\text{s}$	$2\,000 \mu\text{s} \pm 400 \mu\text{s}$
10 Ω load	$-50 \text{ V} \pm 10 \text{ V}$	—	$1\,500 \mu\text{s} \pm 300 \mu\text{s}$

C.2.1.2 Test pulse 1 (Nominal 24 V system)

Table C.2 — Test pulse 1 (Nominal 24 V system)

Test pulse 1	U_s	t_r	t_d
No load	$-600 \text{ V} \pm 60 \text{ V}$	$(3 \begin{smallmatrix} 0 \\ -1,5 \end{smallmatrix}) \mu\text{s}$	$1\,000 \mu\text{s} \pm 200 \mu\text{s}$
50Ω load	$-300 \text{ V} \pm 60 \text{ V}$	—	$1\,000 \mu\text{s} \pm 200 \mu\text{s}$

C.2.2 Test pulse 2

C.2.2.1 Test pulse 2a (Nominal 12 V and nominal 24 V system)

Table C.3 — Test pulse 2a (Nominal 12 V and nominal 24 V system)

Test pulse 2a	U_s	t_r	t_d
No load	$+75 \text{ V} \pm 7,5 \text{ V}$	$(1 \begin{smallmatrix} 0 \\ -0,5 \end{smallmatrix}) \mu\text{s}$	$50 \mu\text{s} \pm 10 \mu\text{s}$
2Ω load	$+37,5 \text{ V} \pm 7,5 \text{ V}$	—	$12 \mu\text{s} \pm 2,4 \mu\text{s}$

C.2.2.2 Test pulse 2b (Nominal 12 V and nominal 24 V system)

Table C.4 — Test pulse 2b (Nominal 12 V and nominal 24 V system)

Test pulse 2b	U_s	t_r	t_d	t_{12}
No load	$+10 \text{ V} \pm 1 \text{ V}$ (12 V system)	$1 \text{ ms} \pm 0,5 \text{ ms}$	$2 \text{ s} \pm 0,4 \text{ s}$	$1 \text{ ms} \pm 0,5 \text{ ms}$
	$+20 \text{ V} \pm 2 \text{ V}$ (24 V system)			

For this verification procedure, U_A shall be set as defined in Table 1.

The wave shape shall be verified under no load condition in general.

Additionally, measurements under load condition shall be carried out by taking the maximum power (the maximum output current I_N of the DC supply into consideration). The minimum usable test impedance is calculated as follows:
 $R_L = U_A / I_N$.

C.2.3 Test pulse 3

C.2.3.1 Test pulse 3a

Table C.5 — Test pulse 3a (Nominal 12 V and nominal 24 V system)

Test pulse 3a	U_s	t_r	t_d
No load	$-200 \text{ V} \pm 20 \text{ V}$	$5 \text{ ns} \pm 1,5 \text{ ns}$	$150 \text{ ns} \pm 45 \text{ ns}$
50Ω load	$-100 \text{ V} \pm 20 \text{ V}$	$5 \text{ ns} \pm 1,5 \text{ ns}$	$150 \text{ ns} \pm 45 \text{ ns}$

C.2.3.2 Test pulse 3b

Table C.6 — Test pulse 3b (Nominal 12 V and nominal 24 V system)

Test pulse 3b	U_s	t_r	t_d
No load	+200 V \pm 20 V	5 ns \pm 1,5 ns	150 ns \pm 45 ns
50 Ω load	+100 V \pm 20 V	5 ns \pm 1,5 ns	150 ns \pm 45 ns

For verification of test pulses 3a/3b coaxial measuring devices shall be used. The spectrum of the pulses covers the frequency range up to 200 MHz. Within this range it is difficult to use high impedance voltage probes. The attached ground cable of the probe may cause significant ringing and may result in false measurements. Coaxial measuring devices therefore are strictly recommended.

Annex D (informative)

Determination of pulse generator energy capability

D.1 Calculation method for determination of energy capability specification

This method is to calculate the energy of the pulse as delivered by the generator to the matching resistor (resistive load R_L) utilising the measured pulse parameters t_d and U_s .

The transient generator used for this part of ISO 7637 should generate double exponential transients, which are a result of capacitive discharges into a pulse shaping network. This type of generator is used for the pulses 1 (12 V), 1 (24 V), 2a, 3a and pulse 3b.

Pulse 2b has to be realized by programmable DC power sources.

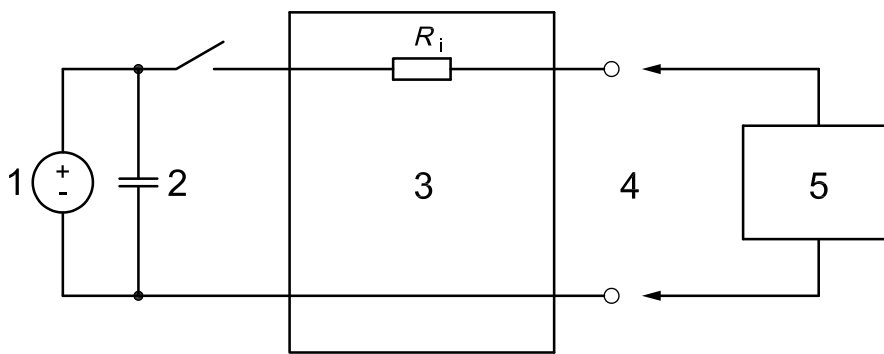

Key

- 1 power supply
- 2 capacitor, C_s
- 3 pulse shaping network with internal resistance, R_i
- 4 pulse output
- 5 matching load resistor, R_L

Figure D.1 — Example of a simplified circuit diagram of a transient generator

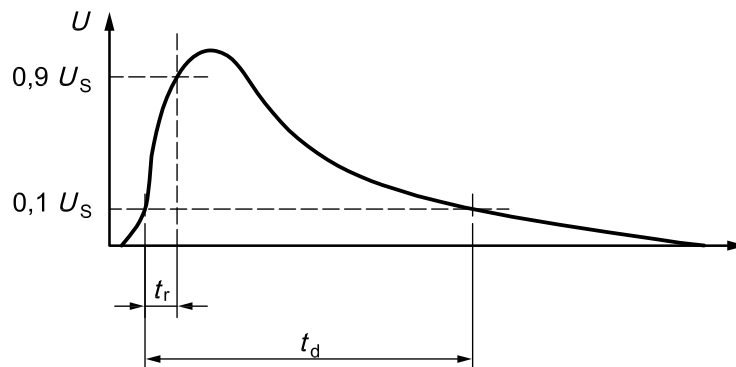

Figure D.2 — Double exponential pulse shape generated by a transient generator

The influence of the rise time is not taken into account ($t_r \ll t_d$), which is allowed for all pulses specified in this part of ISO 7637.

Voltage function:

$$U(t) = \frac{U_O \times R_L}{R_i + R_L} \times e^{-\left(\frac{2,3 \times t}{t_d}\right)}$$

where

U_O is the open circuit output voltage;

R_i is the source resistance of the generator;

R_L is the load resistance for the generator;

t_d is the pulse width 10 % to 10 % of U_S ;

$U(t)$ is a function of the voltage wave shape.

Current function:

$$I(t) = \frac{1}{R_L} \times \frac{U_O \times R_L}{R_i + R_L} \times e^{-\left(\frac{2,3 \times t}{t_d}\right)} = \frac{U_O}{R_i + R_L} \times e^{-\left(\frac{2,3 \times t}{t_d}\right)}$$

where

U_O is the open circuit output voltage;

R_i is the source resistance of the generator;

R_L is the load resistance for the generator;

t_d is the pulse width 10 % to 10 % of U_S ;

$I(t)$ is a function of the current wave shape.

Function of the pulse power:

$$P(t) = U(t) \times I(t) = \frac{(U_O)^2 \times R_L}{(R_i + R_L)^2} \times \left(e^{-\left(\frac{2,3 \times t}{t_d}\right)} \right)^2 = \frac{(U_O)^2 \times R_L}{(R_i + R_L)^2} \times e^{-\left(\frac{4,6 \times t}{t_d}\right)}$$

where

U_O is the open circuit output voltage;

R_i is the source resistance of the generator;

R_L is the load resistance for the generator;

t_d is the pulse width 10 % to 10 % of U_S ;

$U(t)$ is a function of the voltage wave shape;

$I(t)$ is a function of the current wave shape;

$P(t)$ is a function of the pulse power.

Integral of $P(t)$ shows the energy content of a single pulse loaded with R_L :

$$W_e = \int_0^{\infty} P(t) dt = \frac{(U_O)^2 \times R_L}{(R_i + R_L)^2} \times \int_0^{\infty} e^{-\left(\frac{4,6 \times t}{t_d}\right)} dt$$

where

U_O is the open circuit output voltage;

R_i is the source resistance of the generator;

R_L is the load resistance for the generator;

t_d is the pulse width 10 % to 10 % of U_s ;

W_e is the energy content of a single pulse.

This results in a short formula:

$$W_e = \frac{(U_s)^2 \times R_L}{(R_i + R_L)^2} \frac{t_d}{4,6}$$

$$W_e = \frac{(U_s)^2}{(R_L)} \frac{t_d}{4,6} \quad \text{for } R_i = R_L \text{ the voltage } U_O = 2U_s \cdot U_s \text{ is the peak voltage across } R_L$$

where

U_O is the open circuit output voltage;

U_s is the peak voltage;

R_i is the source resistance of the generator;

R_L is the load resistance for the generator;

t_d is the pulse width 10 % to 10 % of U_s ;

W_e is the energy content of a single pulse.

Annex E (informative)

Origin of transients in the electric system of road vehicles

E.1 Introduction

The test pulses used in this part of ISO 7637 are based on pulses measured in vehicle electric systems under certain conditions and created by basic configurations in the electric circuits. The following schematic diagrams show the origin of pulses 1 to 3b. For the evaluation of emitted pulses, see Annex B of this part of ISO 7637.

NOTE Different voltage and impedance values for 12 V and 24 V systems result due to differences in harness structure and switching elements.

E.2 Characteristic pulses

E.2.1 Pulse 1

The schematic circuit diagram that can produce pulse 1 is shown in Figure E.1.

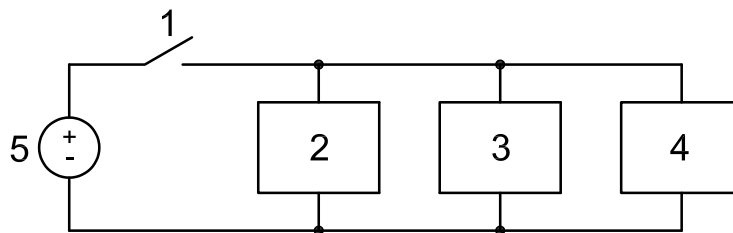

Key

- 1 ignition switch
- 2 inductive load
- 3 load R_s (see 5.2)
- 4 DUT
- 5 power supply

Figure E.1 — Circuit diagram for pulse 1

Pulse 1 occurs due to supply disconnection from inductive loads. This includes blowing or pulling out fuses. It influences devices which remain connected directly in parallel with this inductance. The pulse shape is represented in Figure 5.

Due to the nature of this pulse (DUT power disconnection), events such as reset and/or re-initialization may be accepted in some test plans.

E.2.2 Pulse 2

The schematic circuit diagrams that can produce pulses 2a and 2b are shown in Figure E.2 a) and Figure E.2 b), respectively.

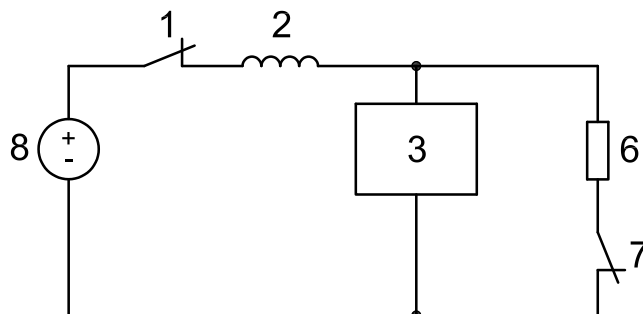

a) Pulse 2a

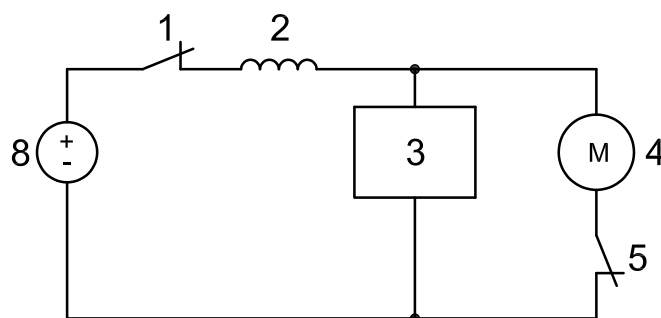

b) Pulse 2b

Key

- 1 ignition switch
- 2 wiring harness (inductive)
- 3 DUT
- 4 DC motor with internal inductance
- 5 motor switch
- 6 load
- 7 load switch
- 8 power supply

Figure E.2 — Circuit diagrams for pulses 2a and 2b

Pulse 2a occurs when the load switch (7) is opened while the ignition switch (1) is closed. This pulse can also occur during blowing or pulling out fuses as well as by bouncing switches.

Pulse 2b occurs when the motor is running and the ignition switch (1) is opened.

The pulse shapes are represented in Figures 6 and 7.

E.2.3 Pulse 3

The schematic circuit diagram of pulse 3 is shown in Figure E.3.

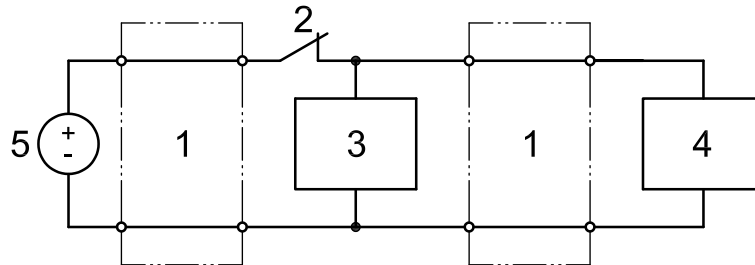

Key

- 1 wiring harness with distributed inductance and capacitance
- 2 switch
- 3 DUT
- 4 inductive load
- 5 power supply

Figure E.3 — Circuit diagram for test pulse 3

Pulse 3 occurs as the result of switching processes. This includes blowing or pulling out fuses. The characteristics of this pulse are influenced by distributed capacitance and inductance of the wiring harness. The pulse shapes are represented by combinations of pulses in Figures 8 and 9.

Annex F (informative)

Alternative transient testing technique using electromechanically switched inductive loads

F.1 General

Voltage transient events are often the result of contact arcing that occurs during mechanical or electromechanical switching of an inductive load. The arcing phenomena produce complex voltage waveforms, whose characteristics (i.e. voltage, pulse duration) are significantly affected by the resistive and reactive loads that share the same circuit as the inductive load.

Characteristics for selected test pulses depicted in this part of ISO 7637 (e.g. pulse 1) represent transient waveforms on DUT power circuits having impedances less than $100\ \Omega$ which is largely due to the input filter capacitances associated with these circuits. However, many microprocessor-based electronic devices have power and input circuits with higher impedances. These higher impedances, when placed across the switched inductive load can result in significantly different voltage transient characteristics. Also, actual transient voltage characteristics are not repetitive by nature and can vary significantly between consecutive transient events. This pseudo-random behaviour can often cause malfunction of DUT software execution.

To simulate these complex waveforms, this annex presents an alternative approach for testing, making use of an electromechanically switched inductive load. The waveforms depicted in this annex represent typical transients produced by a transient generator circuit also defined in this annex. The waveforms serve as guidance for what to expect from the transient generator. All waveforms shown are measured under open circuit conditions unless otherwise stated.

The choice of components used for the transient generator may result in minor differences (e.g. waveform amplitude, timing) between the waveforms illustrated in this annex and the actual transient waveforms produced. However, those differences should not significantly alter the resulting DUT performance during testing.

F.2 Transient waveform description

F.2.1 General

There are three main types of transient waveforms, which have been assigned the designations of A, B and C.

F.2.2 Waveforms A1, A2

Waveforms A1 and A2 simulate voltage transients produced during deactivation of power via mechanical (or electromechanical) switching to an inductive load connected in parallel to the DUT (see Figure F.1). The impedance Z represents other electrical loads that share the same circuit.

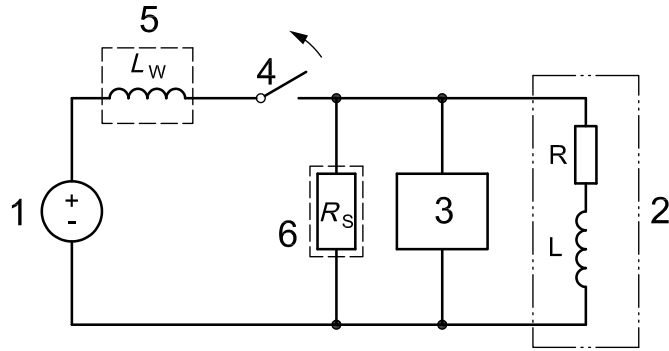

Key

- 1 vehicle battery
- 2 inductive load
- 3 DUT
- 4 switch
- 5 switched inductive load
- 6 shunt resistor according to 5.2

Figure F.1 — Circuit configuration for waveforms A1 and A2

Waveform A1 is produced when switching higher-current (>1 A) inductive loads. The waveform is composed of a long duration component produced by the initial arc discharge across the switch contacts. Note that the timing for the long duration component is directly proportional to the product of the load inductance and the steady state current. The second, shorter duration component is produced by the inductive “fly-back” voltage produced by the remaining stored energy in the inductor after the arc discharge is extinguished.

Waveform A1's open circuit voltage (Z not present) is illustrated in Figure F.2 using the transient generator circuit detailed in F.4. Peak negative open circuit voltage levels may range between -280 V to -500 V. Peak positive open circuit voltage levels are typically between 80 V to 100 V.

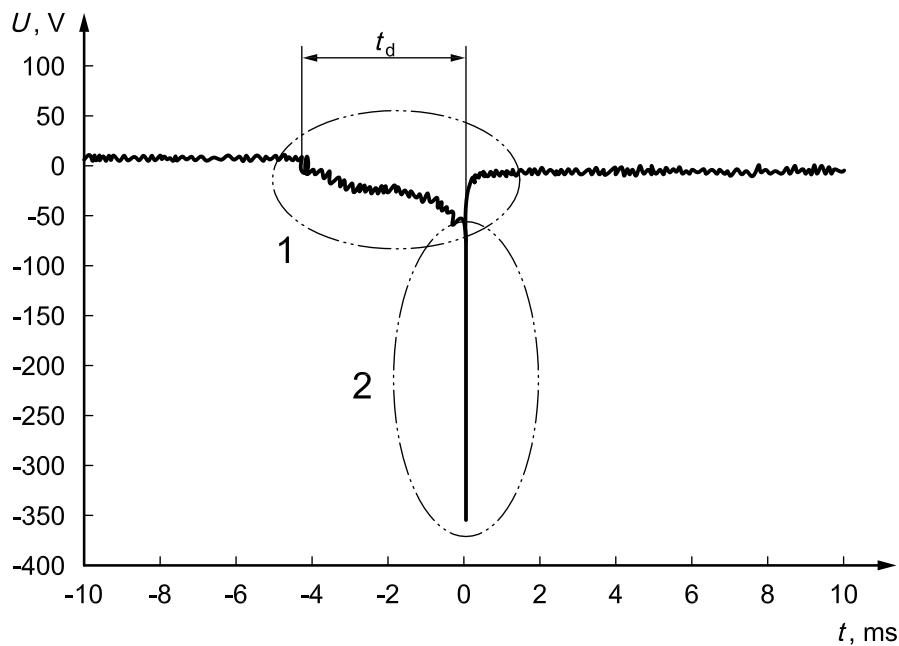

a) Example of A1 composite waveform

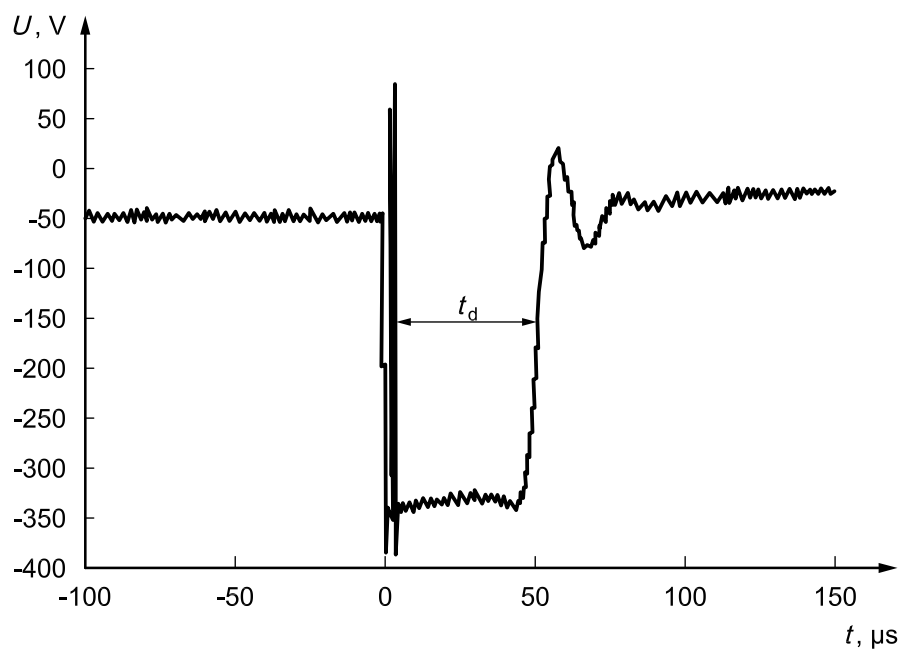

b) Example of A1 short duration waveform component

Key

- 1 long duration pulse component
- 2 short duration pulse component

Examples not to scale.

Figure F.2 — Waveform A1

Waveform A2 (see Figure F.3) is produced when switching predominately low current (<0,4 A) inductive loads, but can also occur, though less frequently, for higher current (>1 A) inductive loads. The waveform is produced during a secondary arc discharge (i.e. “showering arc”) across the switch contacts. The total disturbance time may vary significantly from 20 ms to 400 ms. Duration of individual pulses may vary between 100 ns to 10 ms depending on the parasitic parameters of the inductive load (e.g. inter-winding capacitance). Peak negative voltage levels are between -280 V to -500 V. Peak positive voltages levels for this pulse may be between +100 V to +200 V. Note that the positive transient voltages are the result of the inductance between the battery and the switch.

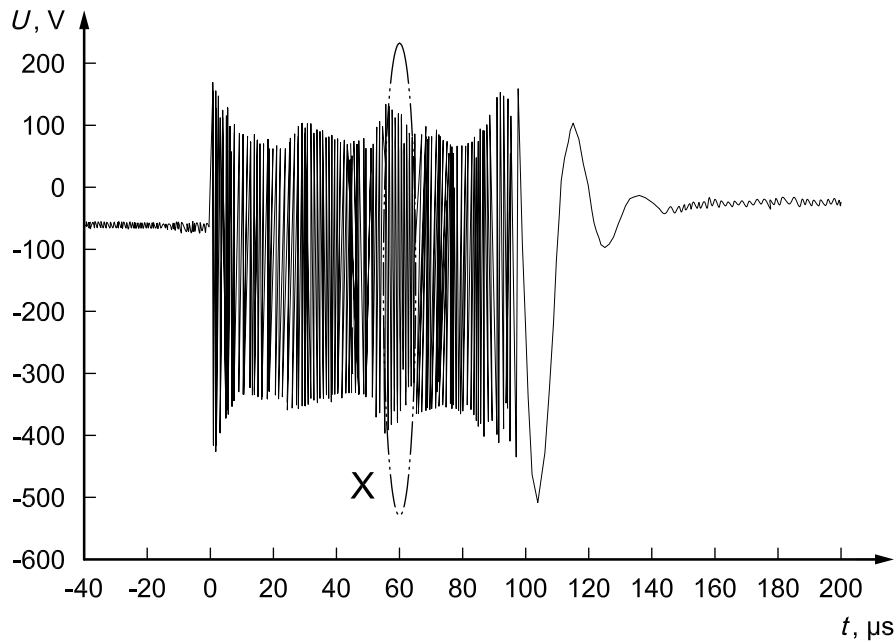

a) Example of A2 composite waveform

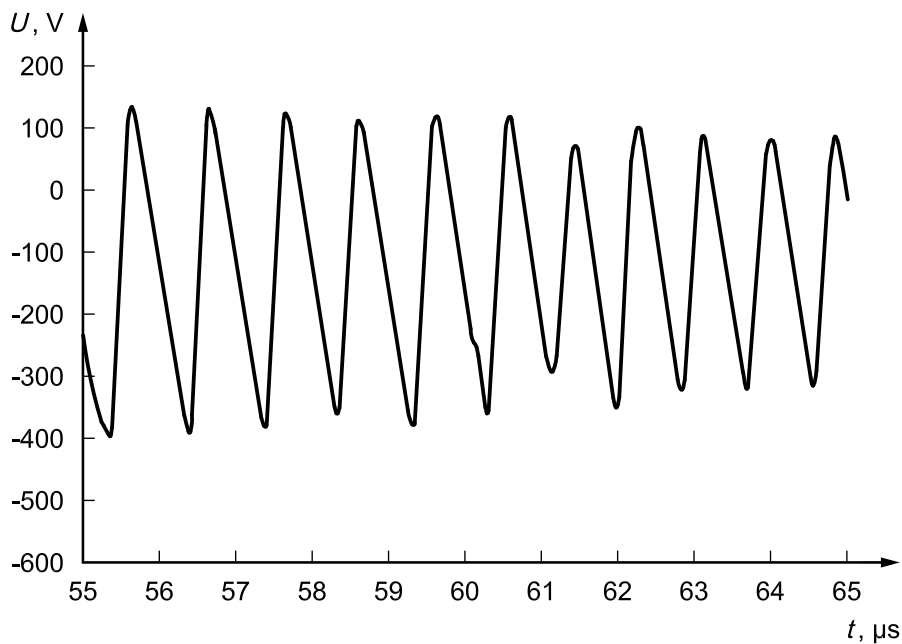

b) Example of waveform A2 detail

Examples not to scale.

Figure F.3 — Waveform A2

Waveform timing and amplitude for Waveforms A1 and A2 are significantly affected by the external circuit loading. Figures F.4 and F.5 illustrate the effect of different loading conditions on A1 and A2 respectively. Note that when the capacitance selected is significant ($\sim 2 \mu\text{F}$), waveform A1 resembles pulse 1 in accordance with this part of ISO 7637.

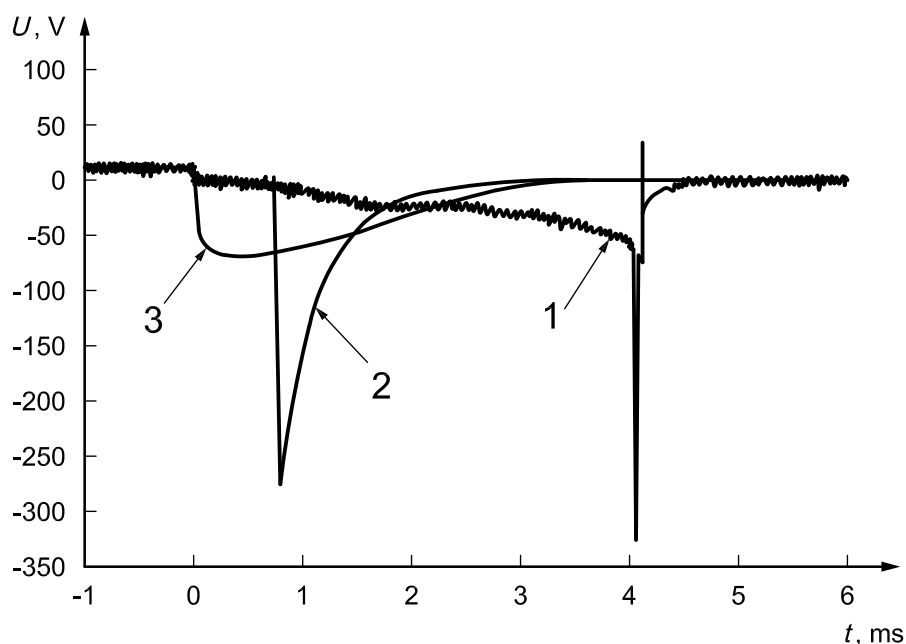

- Key**
- 1 open circuit
 - 2 220 Ω ; 0,1 μF
 - 3 220 Ω ; 2,2 μF

Figure F.4 — External loading effect on waveform A1

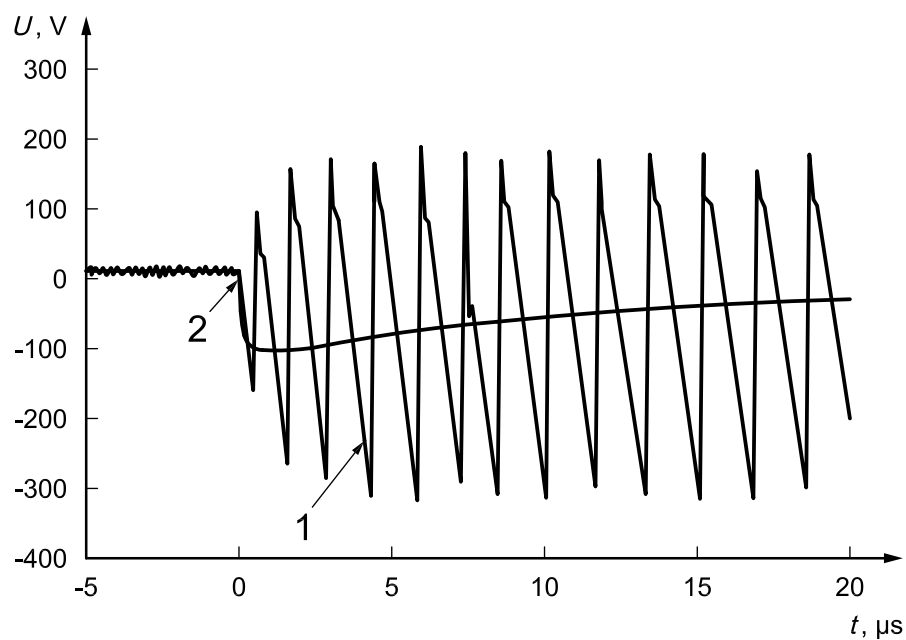

- Key**
- 1 open circuit
 - 2 100 Ω

Example not to scale.

Figure F.5 — Example of external loading effect on waveform A2

F.2.3 Waveforms B1, B2

Waveforms B1 and B2 simulate the voltage transient produced during deactivation via low-side mechanical or electromechanical switching of an inductive load which is connected to an input of the DUT (see Figure F.6).

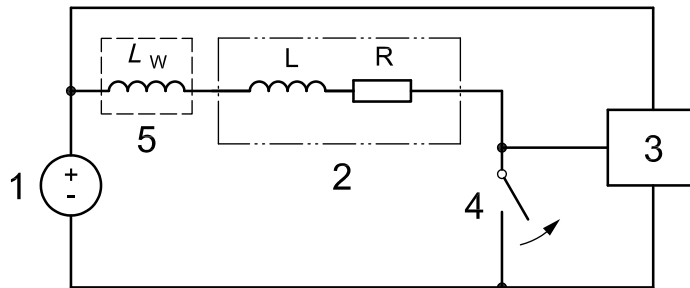

- Key**
- 1 vehicle battery
 - 2 inductive load
 - 3 DUT
 - 4 switch
 - 5 switched inductive load

Figure F.6 — Configuration for waveforms B1 and B2

Waveforms B1 and B2 are similar to waveforms A1 and A2 respectively except the polarities are reversed. This is due to the switching configuration of the inductive load.

F.2.4 Waveform C

Waveform C simulates the voltage transient produced on direct battery connections during switching of predominately low current (<0,4 A) inductive loads (see Figure F.7). The waveform is produced during a secondary arc (“showering arc”) discharge across the switch contacts.

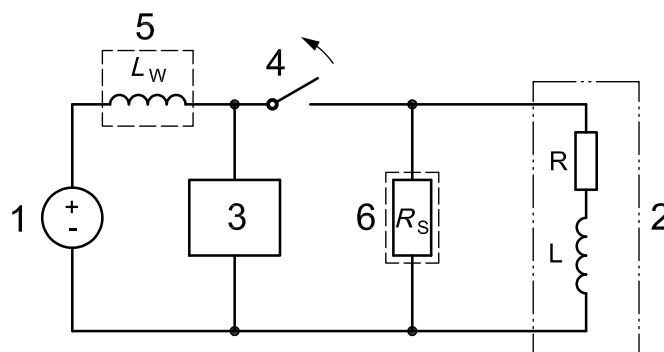

- Key**
- 1 vehicle battery
 - 2 inductive load
 - 3 DUT
 - 4 switch
 - 5 switched inductive load
 - 6 shunt resistor according to 5.2

Figure F.7 — Configuration for waveform C

Waveform C can be significantly affected by any external circuit loading (Z) sharing the same circuit as the inductive load. If the circuit loading is selected such that shower arcing does not occur, waveform C will not exist.

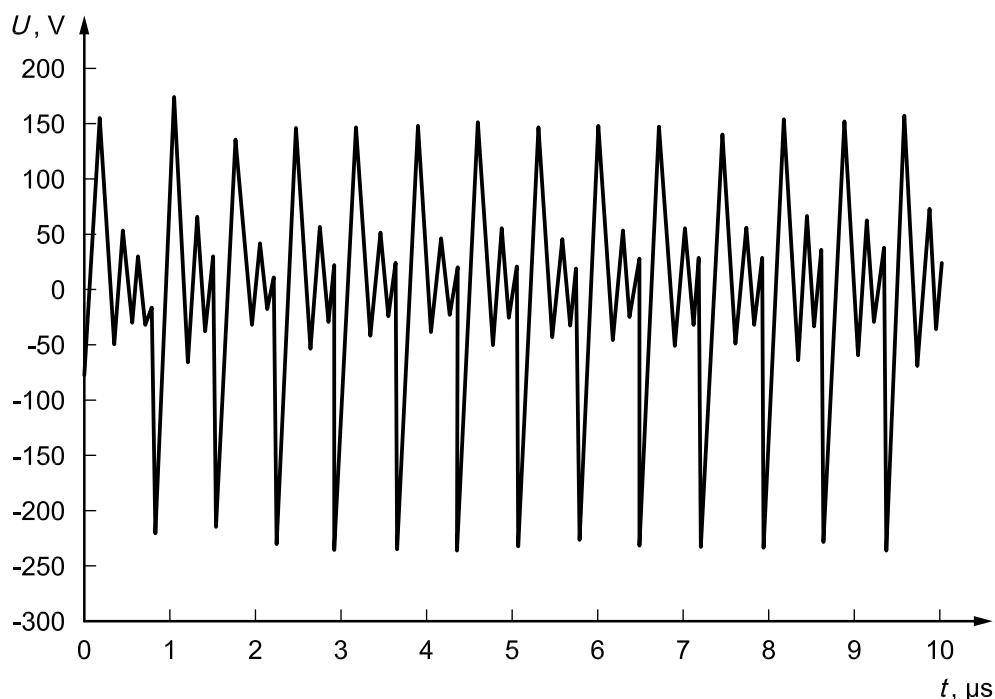

Example not to scale.

Figure F.8 — Example of waveform C characteristics

F.3 Application of transient waveforms

The recommended application of the test waveforms, described in F.2, to DUT circuits is presented in Table F.1. Note that in addition to the locations where these transient waveforms are to be applied, there are two operating modes of application. In Mode 1, test waveforms are applied at a fixed repetition rate. In Mode 2, test waveforms are applied in a pseudo-random manner. The purpose for Mode 2 is to verify that pseudo-random transient disturbances do not cause disruption of DUT software execution, which is less likely to occur when exposing the DUT to repetitive pulses.

The pulses are applied using the transient waveform generator circuit detailed in F.4. For each waveform, one or both modes may be used except for waveforms B1 and B2, due to a limitation of the generator circuit.

F.4 Transient waveform generator circuit

Transient waveforms A1, A2, B1, B2, and C are generated using the circuits illustrated in Figures F.9 and F.10. The circuits contain a few key components that can affect the waveform characteristics depicted in F.2. However, the differences between the waveforms depicted in this annex and actual transient waveforms produced will be minor.

The circuit facilitates generation of transient pulses in either Mode 1 or Mode 2. Mode 1 consists of repetitive pulses with a pulse repetition rate (PRR) of, e.g., 0,1 Hz, 10 % duty cycle. The sub-circuit illustrated in Figure F.11 a) facilitates Mode 1 pulses. Mode 2 consists of pseudo-random pulses that are generated by the sub-circuit illustrated in F.11 b). Note that Mode 2 cannot be used when applying either pulse B1 or B2.

Table F.1 — Test waveform application

Test pulse	Pulse application	Mode ^a
A1, A2	DUT power supply circuits that are connected to the vehicle battery via mechanical switches or electromagnetic relays. DUT input circuits that are connected directly or indirectly (e.g. pull-up resistor) to the vehicle battery via mechanical switches or electromechanical relays.	1, 2
B1, B2	DUT input circuits connected to low-side switched inductive loads.	1
C	Component power supply circuits that are directly connected to the vehicle battery (i.e. no switches). Component power supply circuits when connected to the vehicle battery via mechanical switches (e.g. ignition switch) and electromagnetic relays. Input circuits when connected directly or indirectly (e.g. pull-up resistor) to the vehicle battery via mechanical switches (e.g. ignition switch) and electromagnetic relays.	1, 2

^a Mode 1: Waveforms are applied at a repetition rate of e.g 0,1 Hz, 10 % duty cycle (see F.4).
Mode 2: Waveforms are applied using a pseudo-random repetition rate (see F.4).

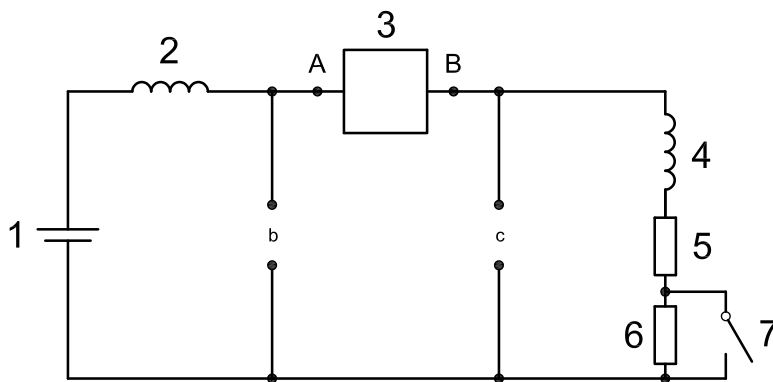

Key

- 1 vehicle battery (12 V DC)
- 2 inductor: 5 μH (50 A)^a
- 3 relay sub-circuit [see Figures F.11 a) and F.11 b) for detail]
- 4 inductor: 100 mH (2 A) (DC resistance <1 Ω)
- 5 resistor: 6 Ω ±5 %
- 6 resistor: 100 Ω ±5 %
- 7 switch: SPST (2 A)
switch closed for pulse A1
switch open for pulses A2 and C

NOTE 1 The switch (7) is open during application of waveforms A2 and C. The switch is closed during application of waveform A1.

NOTE 2 Pairs of points A1, A2 and C are the DUT connection points for pulses A1, A2 and C, respectively.

- ^a Current rating on 5 μH inductor based on expected current draw of DUT plus 2 A from the 100 mH inductive load.
- ^b DUT connection for pulse C.
- ^c DUT connection for pulses A1 and A2.

Figure F.9 — Generator circuit for pulses A1, A2 and C

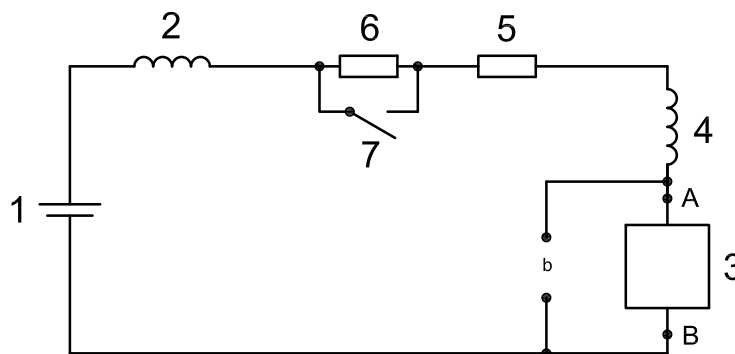
**Key**

- 1 vehicle battery (12 V DC)
- 2 inductor: 5 μ H (50 A)^a
- 3 relay sub-circuit [see Figure F.11 a) and F.11 b) for detail]
- 4 inductor: 100 mH (2 A) (DC resistance <1 Ω)
- 5 resistor: 6 Ω \pm 5 %
- 6 resistor: 100 Ω \pm 5 %
- 7 switch: SPST (2 A)
 - switch closed for pulse B1
 - switch open for pulse B2

NOTE 1 The switch (7) is open during application of waveform B2. The switch is closed during application of waveform B1.

NOTE 2 Pairs of points B1 and B2 are the DUT connection points for pulses B1 and B2, respectively.

^a Current rating on 5 μ H inductor based on expected current draw of DUT plus 2 A from the 100 mH inductive load.

^b DUT connection for pulses B1 and B2.

Figure F.10 — Generator circuit for pulses B1 and B2

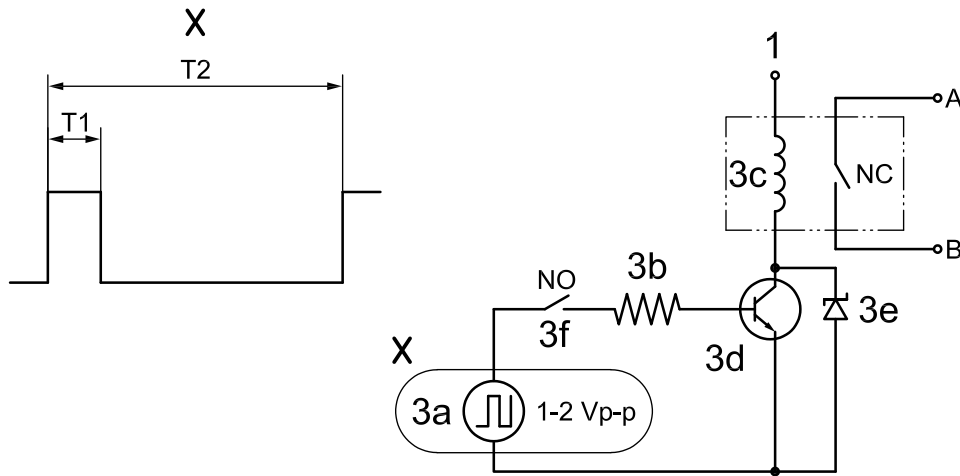

a) Mode 1

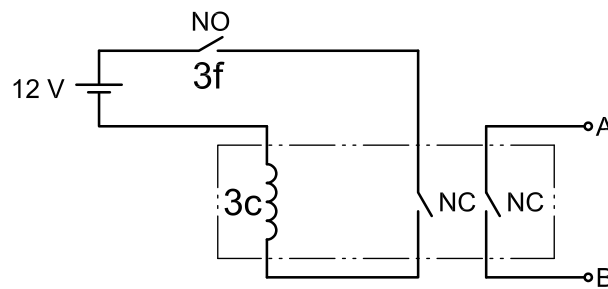

b) Mode 2

Key

- 1 vehicle battery connection
- 3a function generator (e.g. 0,1 Hz square wave)
- 3b resistor: 51 Ω 0,25 W
- 3c 12 volt AC relay (double pole)^a
- 3d NPN transistor: TIP 41
- 3e Zener diode: 39 V, 5 W (1N5366A)
- 3f test switch: SPST switch

^a Use of 12 volt AC relay is critical in order to achieve pseudo-random switching behaviour for Mode 2 operation. Switching shall be performed using a single contact.

Figure F.11 — Relay sub-circuit

Bibliography

- [1] ISO 8854, *Road vehicles — Alternators with regulators — Test methods and general requirements*
- [2] ISO 16750-2, *Road vehicle — Environmental conditions and testing for electrical and electronic equipment — Part 2: Electrical loads*
- [3] ISO 21848, *Road vehicles — Electrical and electronic equipment for a supply voltage of 42 V — Electrical loads*

